

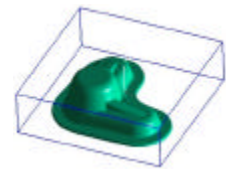

UGS Users Meeting

Portoroz / Slovenija
Monday, 26. March 2001



Infomaterial UG

CAM using the Master Model Concept

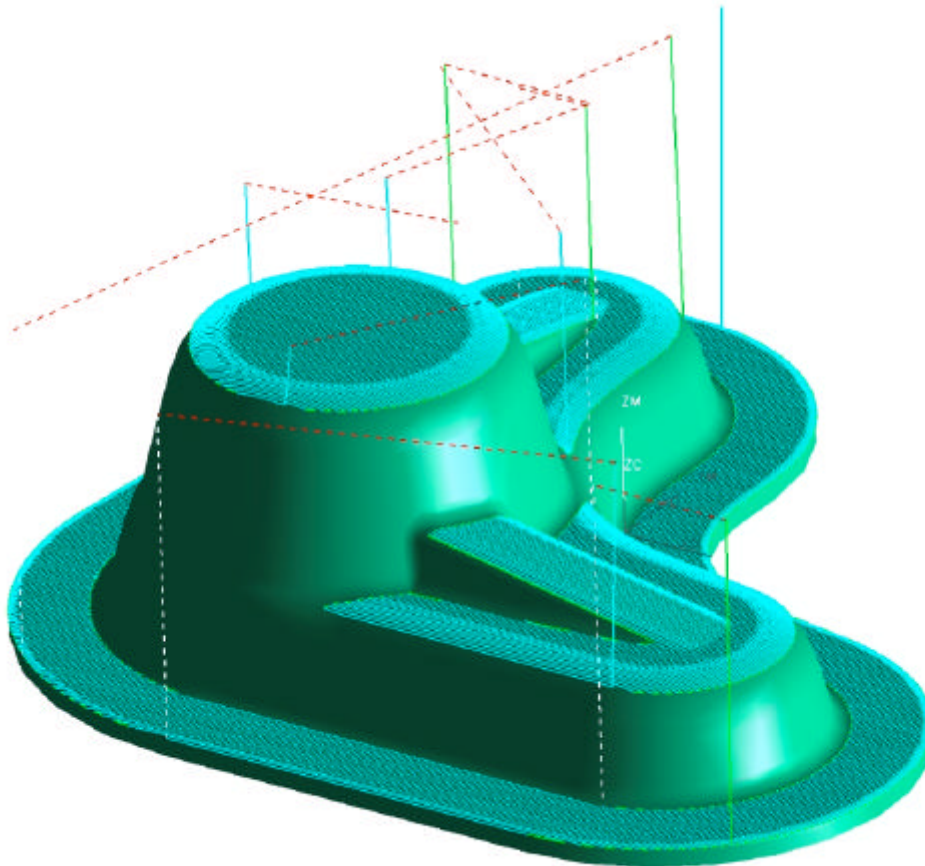

INTREX, International Trading Exquisit
dept. CAD/CAM-Services

Ing. Torbjörn JOHANSSON
Waldgasse 22

A - 8700 Leoben, Austria

Tel. +43 - 664 - 3414336

Fax: +43 - 3842 - 27930

<http://www.intrex.at>

tj@intrex.at



UGS Users Meeting

Portoroz / Slovenija
Monday, 26. March 2001

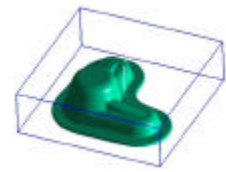

CAM-Master Model Concept (MMC):

- Normal assembly

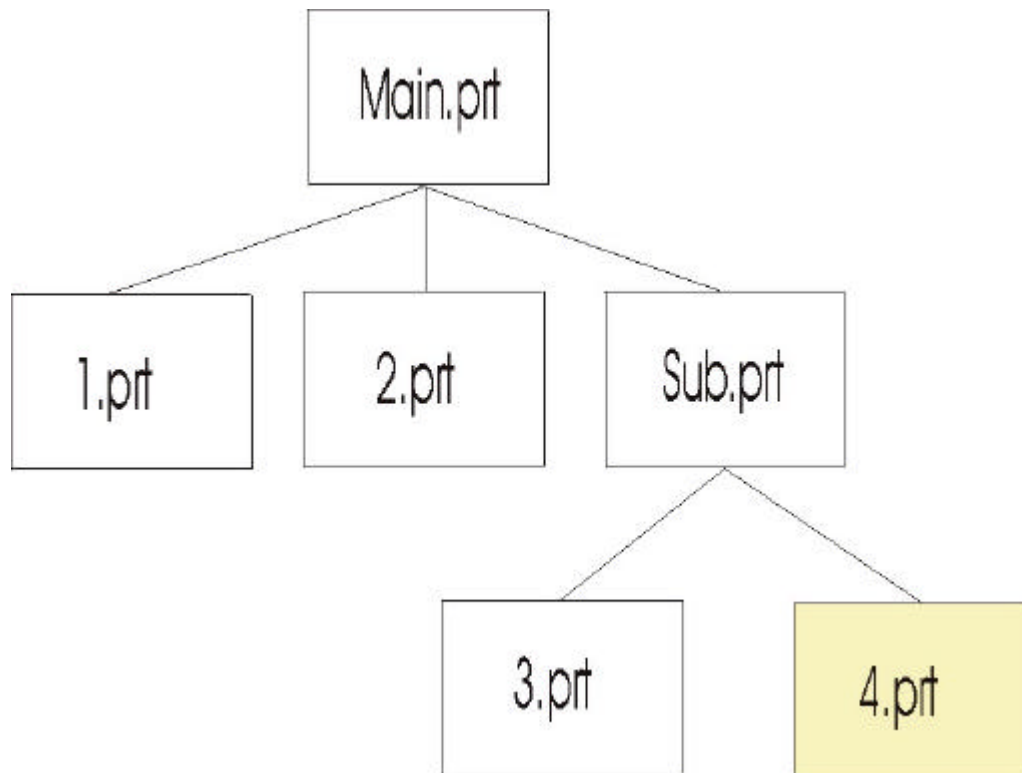

- If you work the “classic“ way, you put all your data (CAM-data, drafting data and so on) in the above structure, this way the size of the whole assembly will grow rapidly.
- With the Master Model Concept, you put all “extra“ data outside your geometry assembly, letting this stay small in size.

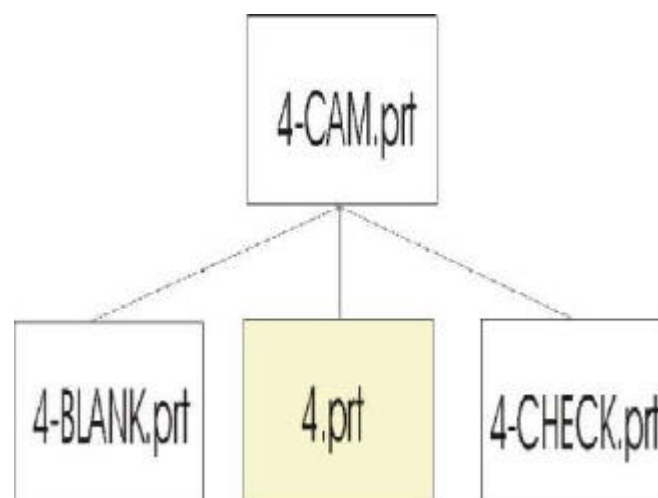



UGS Users Meeting

Portoroz / Slovenija
Monday, 26. March 2001

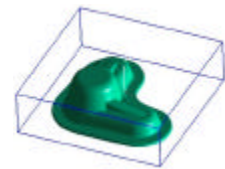

- The whole structure then looks like this:

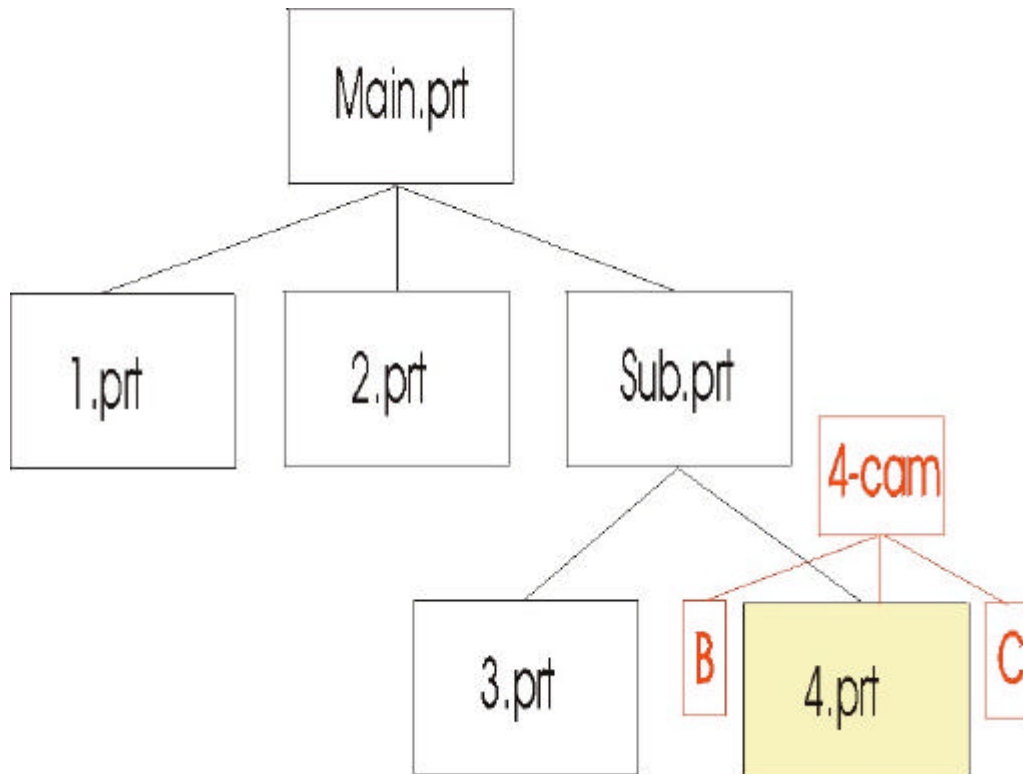

- Since the assembly works top→down when loading, opening the main.prt lets your CAM-data unloaded, and you don't need to waste memory on things you don't need at the moment.
- When you open the CAM-part, you only load the CAM-data, leaving the rest of the assembly unloaded.
- Just remember to have the CAM-part as your workpart, saving all CAM-data in it!
- See the picture below (mmc-001.....prt, containing only 1 operation!) for comparison. The original file, mmc-001.prt, is still small and handy!

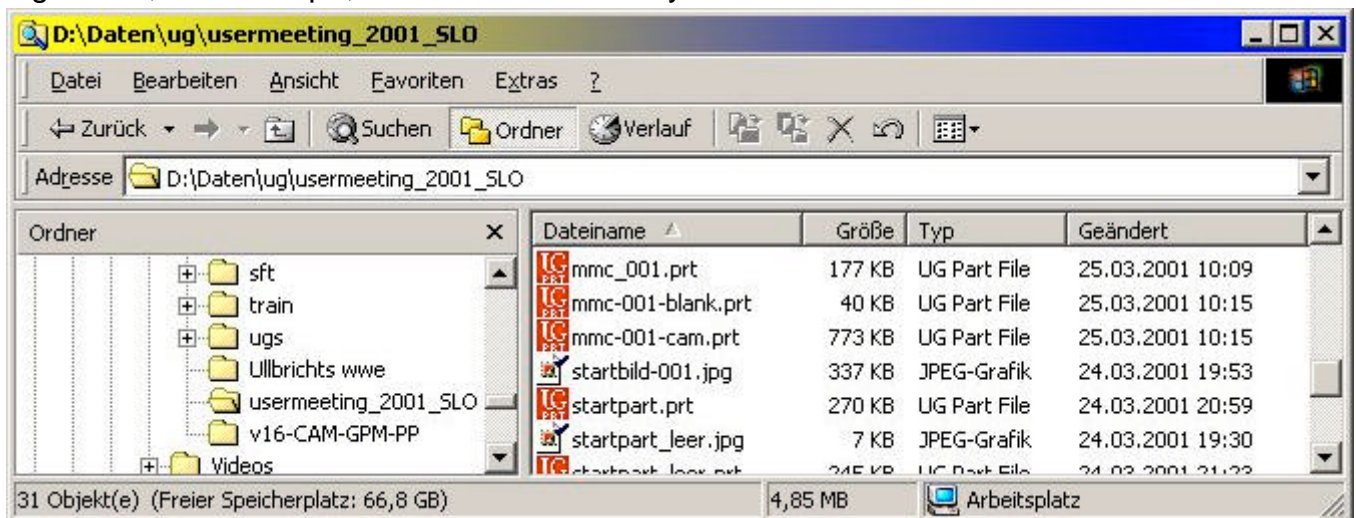



UGS Users Meeting

Portoroz / Slovenija
Monday, 26. March 2001

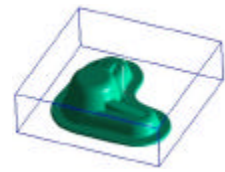

Your possibilities with us

With our partners we can help you in everything from design (UG, but also native AutoCAD and Catia), up to final prototypes (Rapid Prototyping, STL, SLA, prototype moulding & casting, milling 3-5 axis)

As a partner of UGS-Austria, we have all the possibilities you need for your buisnesses.

We do:

- 2D – 3D Design
- Data conversion
- 3 – 5 axis milling
- Rapid Prototyping
- Trainings & Workshops
- Installations

Please do not hesitate to contact us!

INTREX, International Trading Exquisit
dept. CAD/CAM-Services
Ing. Torbjörn JOHANSSON
Waldgasse 22
A - 8700 Leoben, Austria
Tel. +43 – 664 – 3414336
Fax: +43 – 3842 – 27930
<http://www.intrex.at>
tj@intrex.at